

# ATSC Master™ II FD-RS

ATSC (SMPTE 310M), PCI Interface  
With A or B Selectable Inputs,  
Dual Outputs, Accurate Clock, Internal  
Serial Numbers, PID Filtering, Snoop and  
Watchdog Functions, Internal Loopback,  
External Loop Through, GPIO Triggers,  
Secondary Input via Header, and Failover  
Relay

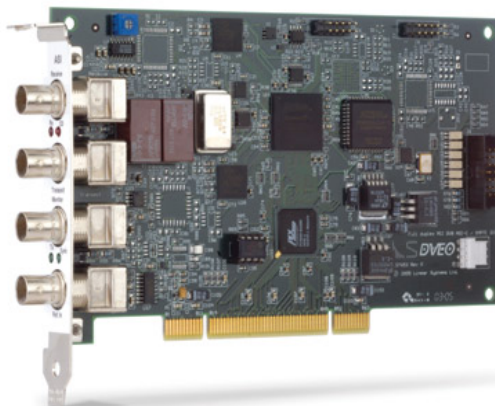

a t s c  
Advanced Television Systems Committee

## Features

- Windows® API and Linux® SDK
- 33/66 MHz 32 bit universal PCI interface
- Two SMPTE 310M Inputs -- Primary BNC and secondary via header
- Two buffered mirrored SMPTE 310M outputs
- Software control of primary or secondary input source selection
- Mechanical relay bypass on power failure
- Software controlled firmware loop-back bypasses the primary input to both outputs
- “Snoop” function for reading input data while in firmware bypass
- On-board circuitry to monitor transport stream quality
- Control Interface port
- 6 general purpose optically isolated inputs
- Status output for firmware loop-back
- Rx and Tx status indicators via LEDs
- External override input for the bypass relay
- Software readable, unique serial number on each board
- Field upgradeable firmware
- Software selectable transmit clock source
- External clock input, 38 MHz PECL signal

## Highlights

- Designed to replace the venerable ATSC Master FD
- New functions – mechanical bypass on power failure, secondary input, and watchdog timer
- Ideal for mission critical broadcast applications

## Overview

In North America and in certain other countries, SMPTE 310M has been designated as the standard for digital television and the delivery of MPEG-2 transport streams via 8VSB modulated signals. ATSC is the name of the organization that defined this specification, and SMPTE 310M is the standard which the transport stream must meet in order to interface to 8VSB modulators.

The ATSC Master II FD-RS is a PCI I/O card that meets the SMPTE 310M electrical specifications. It is designed to provide an interface for importing and exporting MPEG-2 transport streams from a PC. Please note that to be a valid ATSC transport stream, the stream must total 19.39 Mbps. It may be a single or a multi-program transport stream. *Our card is designed to deliver such a stream with a very accurate clock rate and with the proper signaling methodology;* thus we can claim to be SMPTE 310M compatible.

Please note that valid ATSC transport streams not only must meet encoding rate standards, but certain meta tables must be appended to the streams. The ATSC Master II FD-RS assumes that such tables are present and makes no alteration of the incoming or outgoing transport streams. It only looks at the data format, and the presence of a valid transport stream.

**DVEO**  
Broadcast Division

Computer Modules, Inc.

11409 West Bernardo Court

San Diego, CA 92127

Tel: (858) 613-1818 Fax: (858) 613-1815

[www.dveo.com](http://www.dveo.com)

## Capabilities

- When used with a PC, ATSC Master II FD-RS will capture MPEG-2 transport streams for future playback or offline analysis using a bit-stream analyzer
- Outputs transport packets for use in an ATSC broadcast chain or multiplexer
- Both transmitter and receiver on the same card

## Development Software

- Drivers for Windows® 7 32 and 64 bit, Server 2003, Server 2008, Windows® 2000, and Windows® XP
- Synchronous API – API for Windows
- Linux® Master Driver and SDK

## Block Diagram

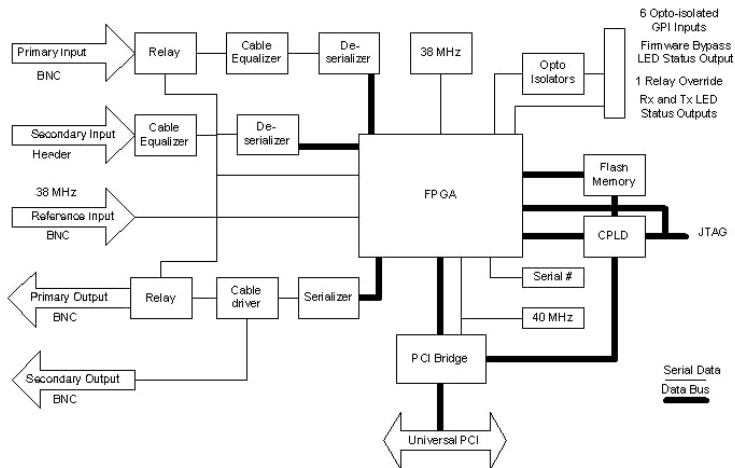

## Specifications

<b>Input/Output Connectors</b>	75-Ohm BNC Connector
<b>Coaxial Cable Type</b>	75-Ohm impedance usable up to 850 MHz
<b>External Clock Input</b>	75-Ohm DC Blocked ECL
<b>Data Input/Output</b>	SMPTE 310M -1998 8VSB Transport Stream
<b>Data Rate</b>	19,392,658.46 bps
<b>Data Input Voltage</b>	800 mV ± 10% Peak
<b>Data Input Offset</b>	0.0 V ± 0.5 V
<b>Bus Interface</b>	Universal 32-bit PCI
<b>Card Size</b>	6.875 x 4.2 inches (175 x 107 mm)
<b>Voltage Requirements</b>	+5 V
<b>Operating Temperature</b>	0° to 55°C
<b>Operating Humidity</b>	To 90%, non-condensing
<b>Clock Source Selection</b>	Software controlled
<b>Driver Support</b>	Windows® 7 – 32 and 64 bit, Windows XP, Windows Server 2003, Windows Server 2008, and Linux®

## Applications

- Transporting of MPEG-2 over long distances meeting FCC requirements
- Moving MPEG-2 transport stream to/from the PCI bus for processing
- Interfacing MPEG-2 to PCI bus encoder/decoder boards
- Interfacing to general studio equipment
- Interfacing to video servers

## Connector Diagram

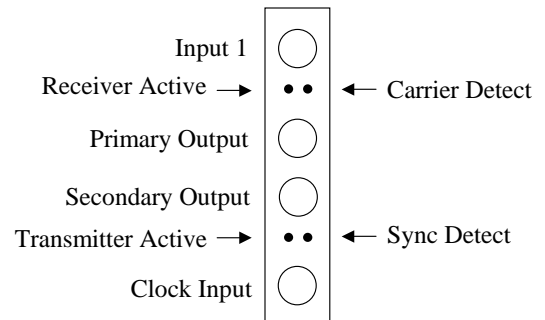

## Ordering Info

ATSC Master II FD- RS  
(Model 113)

© 2011 Computer Modules, Inc. DVEO, Computer Modules, and ATSC Master II FD-RS are trademarks of Computer Modules, Inc. All other trademarks and registered trademarks are the properties of their respective owners. All rights reserved. Specifications are subject to change without notice.

**DVEO**  
Broadcast Division

Computer Modules, Inc.

11409 West Bernardo Court

San Diego, CA 92127

Tel: (858) 613-1818 Fax: (858) 613-1815

[www.dveo.com](http://www.dveo.com)