

# DVB Master™ III Rx PCIe

**Enhanced DVB-ASI PCI Express  
Receive Interface Card with Automatic  
Packet Conversion, Automatic Null  
Packet Insertion, Unlimited PID  
Filtering, and Packet Arrival  
Timestamping**

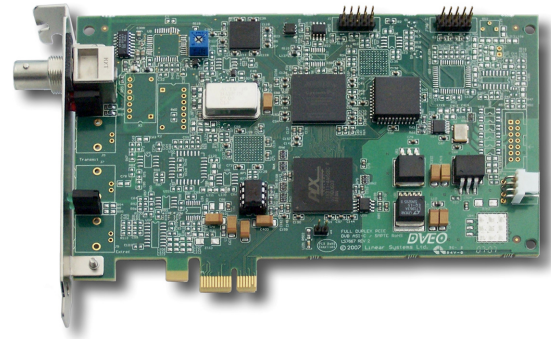

## Features

- 213 Mbps DVB-ASI receiver on a PCIe card
- Hardware based packet arrival timestamping to help with PCR jitter measurement
- PCIe 1.0a interface bus
- Automatic Cable Equalization
- Automatic stuffing of null packets via firmware
- Jitter minimization in hardware
- Reed-Solomon conversion (Optional FEC stripping)
- Drivers for Windows® 7 – 32 and 64 bit, Server 2003, Server 2008, Windows® 2000, Windows® XP, and Linux®
- Windows® XP/Server 2003/Server 2008/ Linux® API
- DirectShow® filter
- Advanced Receiver Capabilities –
  - Synchronizes incoming packets to byte boundaries
  - Interrupt on in/out of sync
  - Software selectable option to strip 16 bytes from 204 byte packets
  - Unlimited PID filtering (any number of PIDs may be selected)

## Applications

- Capture transport streams to disk
- MPEG-2 Transport Stream Video Server/Analyzer/Monitor
- MPEG-2 Transport Stream Repurposing
- PID filtering of transport streams
- MPEG-2 archiving
- MPEG over IP
- IP over MPEG data encapsulation
- Test equipment (analysis and capture)

## Overview

DVB-ASI is a physical interconnect standard created by the international standardization group known as the DVB Project ([www.dvb.org](http://www.dvb.org)). It is designed to carry MPEG-2 transport streams between devices at a maximum rate of 213 Mbps. The actual signaling rate of DVB-ASI is 270 Mbps, but there is overhead from the data encoding scheme and the maximum payload ends up being approximately 213 Mbps.

Transport streams are essentially packetized MPEG streams with tables embedded every 100 ms or so, which tell the ultimate MPEG decoder how to decode the stream.

Furthermore, transport streams may be combined or multiplexed to create multiprogram transport streams with separate PIDs, or program identifiers, that distinguish them as “channels” do in analog television.

We have incorporated as many features as possible into this PCIe card. With all these features, our customers can create very powerful workstations that can process transport streams “on the fly” for applications such as broadcasting, cable TV, satellite links, video servers, and distance learning.



**Computer Modules, Inc.**

**11409 West Bernardo Court**

**San Diego, CA 92127**

**Tel: 858-613-1818 Fax: 858-613-1815**

[www.dveo.com](http://www.dveo.com)

## Specifications

<b>Dimensions</b>	
Width:	4.4 in (11.18 cm)
Length:	6.6 in (16.76 cm)
Thickness:	0.66 in (1.68 cm)
<b>Typical Weight</b>	3.9 oz (110g)
<b>Input Connectors</b>	75 Ohm BNC
<b>Data Input</b>	DVB-ASI Coaxial, 2 kbps to 213 Mbps Data Rate
<b>Power Requirements</b>	12V/3.3V, 80mA @ 3.3V, 15mA@12V
<b>Operating Temperature</b>	0 to 55° C
<b>Operating Humidity</b>	To 90%, Non-condensing
<b>Status LED Indicators</b>	Rx, Carrier Detect, Sync
<b>Receive FIFO Size</b>	2 KBytes
<b>Bus Interface</b>	Single Lane (x1) PCIe 1.0a
<b>Driver Support</b>	Windows® 7 – 32 and 64 bit, Server 2003, Server 2008, Windows® 2000, Windows® XP, and Linux®

## Block Diagram

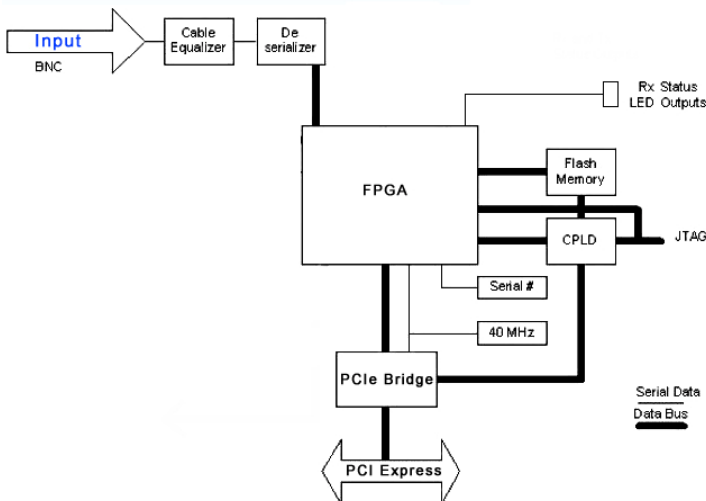

## Ordering Information

DVB Master III Rx PCIe

© 2011 Computer Modules, Inc. DVEO and DVB Master are trademarks of Computer Modules, Inc. DVB is a registered trademark of the DVB Project. All other trademarks and registered trademarks are the properties of their respective owners. All rights reserved. Specifications are subject to change without notice.

## Capabilities

**Receive Packet Synchronization** – The **DVB Master III Rx PCIe LP** will check the incoming transport stream for packet sync, and synchronize on it. Once synchronized, the packets will be stored on packet boundaries in memory. This makes further processing of the transport stream much easier for the host processor. When the board is synchronized on a valid stream the red “Rx Data” and green “Sync” LEDs will be illuminated.

**Packet Arrival Timestamping** – Each packet is timestamped with an arrival time generated by an internal timer/counter. Hardware based packet arrival timestamping is also useful for controlling retransmission.

**Null Packet Insertion** – Under software control but performed by hardware, "null packets" are automatically inserted to replace PID packets that are removed via the PID packet filtering option.

**Indicator LEDs** – Indicator LEDs are provided on the bracket to show receiver operation. The LED will flash to indicate when valid data is being received on that channel.

**In/Out of Sync Interrupt** – An interrupt will be generated whenever synchronization is lost or recovered. Interrupts are generated when there are changes in the stream and indicate that the status of the stream should be checked.

**Reed-Solomon Conversion (Automatic Packet Size Conversion)** – The software can be set to have hardware remove 16 bytes from 204 byte packets to make 188 byte packets.

**PID Filtering** – This function allows you to select any number of PIDs from the total of over 8,000 possible PIDs to be filtered from the stream. The **DVB Master III Rx PCIe LP** receiver channels will block all PIDs that are not selected.

**Conformity to DVB Standards** – The **DVB Master III Rx PCIe LP** meets CENELEC EN50083-9: 1998 – Cable distribution systems for television, sound and interactive services – Part 9: Interfaces for CATV/SMATV headends and similar professional equipment for DVB/MPEG-2 transport streams.

**Customizability** – Room in large FPGA for your custom functions.

**DVEO**  
Broadcast Division  
Computer Modules, Inc.  
11409 West Bernardo Court  
San Diego, CA 92127  
Tel: 858-613-1818 Fax: 858-613-1815  
[www.dveo.com](http://www.dveo.com)