

DVB Master™ Quad/o PCIe LP

Quad Channel DVB-ASI Low Profile PCIe Output Card with Enhanced Rate Control and Jitter Management on Each Port

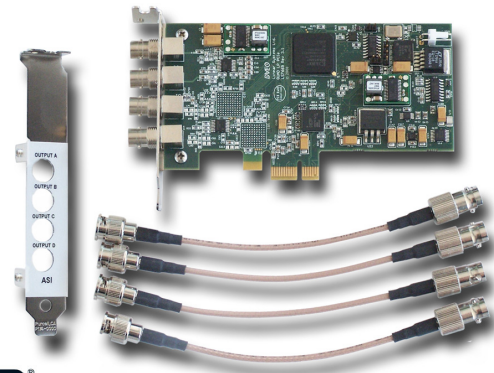

Features

- Four transmitter channels on the same PCI Express low profile card
- Aggregate data rate to 852 Mb/s
- Single Lane PCI Express v1.1 interface
- Multiple boards can be used for more outputs
- Looks like 4 separate DVB Master™ III Tx's
- Uses highly efficient Bus Master Link List DMA for data transform (saving CPU resources)
- Provides an interface for Layer-0 & Layer-1 of the DVB ASI standard
- RoHS compliant (2002/95/EC)
- External clock input via NTSC or PAL black burst signal (available from on-board header)
- Unique silicon serial number
- Firmware is field upgradeable
- Drivers for Windows® 7 32 and 64 bit, Server 2003, Server 2008, Windows® 2000, Windows® XP, and Linux®
- Windows® XP/Server 2003/Server 2008/Linux® API
- DirectShow® filter
- Advanced Transmit Capabilities –
 - Enhanced transmit rate “Fine Tuning” control to <2.8ppm granularity
 - Software selectable option to add sixteen – 0x00 bytes to 188 byte packets
 - External transmit clock inputs (black burst or external reference clocks)
- Black burst input on header
- Mini-BNC to BNC adapter cables included

Applications

- DVB VoD (Video on Demand) Servers
- Cable TV
- Broadcast TV

Overview

Worldwide the television industry is currently in the process of changing from analog to digital technology. MPEG-2 has now been universally adopted as the main standard for video compression. Since MPEG-2 must be decoded at the same rate it was encoded, an information layer needs to be added to the MPEG in order to transmit it to end users. Standards have been created by industry to provide for the methodology of packetizing MPEG-2 streams and adding encoding information in tables via data packets to the video packets. The DVB standard has been approved by the European Community and other industry and government groups as the standard to accommodate the need for satellite and terrestrial originated digital television. This product complies with the DVB-ASI specifications as defined in ETSI TR 101 891 and provides for the ability of computers to capture, process, and transmit DVB-ASI compliant streams.

DVB-ASI streams are routinely used to send and receive transport streams between different brands of equipment. These transport streams can be single program transport streams or multiprogram transport streams. Interestingly, RF modulators determine the maximum size of transport streams. QAM modulators can handle 38 Mbps, 8VSB modulators can handle 19.3 Mbps, and DVB-S2 can handle over 60 Mbps. Of course IP backbones can routinely transfer 100 Mbps transport streams. It is also worthwhile to note that H.264 streams can be embedded into any MPEG-2 stream. Our DVB-ASI interface cards can handle them all.



Computer Modules, Inc.

11409 West Bernardo Court

San Diego, CA 92127

Tel: 858-613-1818 Fax: 858-613-1815

www.dveo.com

Specifications

Dimensions	
Width:	2.7 in (6.85 cm)
Length:	4.8 in (12.19 cm)
Thickness:	0.58 in (1.47 cm)
Typical Weight	2.6 oz (75 g)
Output Connectors	75 ohm mini-BNC
External Clock Input	75-Ohm NTSC/ PAL Blackburst (header)
Data Output	DVB-ASI Coaxial, 2 Kbps to 213 Mbps data rate
Typical Power	500 mA @ 3.3V; 25 mA @ 12 V
Operating Temperature	0 to 55° C
Operating Humidity	To 90%, Non-condensing
Status LED Indicators	Tx
Transmit FIFO Size	8 KB per channel
Bus Interface	Single Lane (x1) PCIe 1.1

Block Diagram

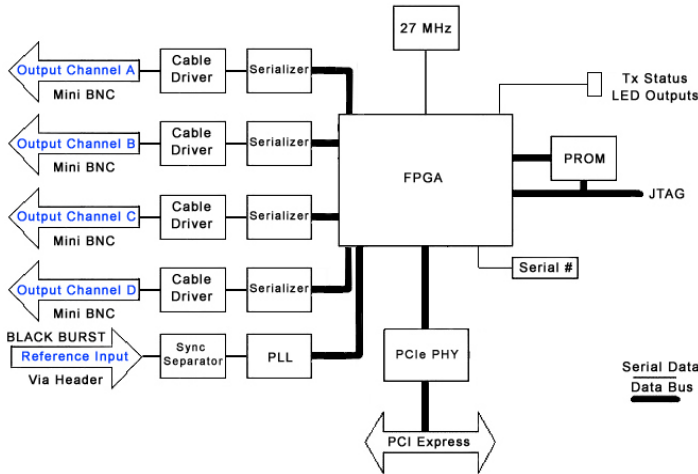

Ordering Information

DVB Master Quad/o PCIe LP (Model 172)

© 2012 Computer Modules, Inc. DVEO and DVB Master are trademarks of Computer Modules, Inc. DVB is a registered trademark of the DVB Project. All other trademarks and registered trademarks are the properties of their respective owners. All rights reserved. Specifications are subject to change without notice.

Capabilities

Transmitter Fine Tuning – The normal inter-byte (IB) and inter-packet (IP) stuffing options available with the DVB ASI standard cannot be used for fine rate control. In some applications, such as reading files from a disk, it may be desirable to use stuffing to control the transmission rate of the stream in order to match the rate required by the Program Clock Reference (PCR) of a Transport Stream. Because of this, we have developed the Fine Tuning (FT) feature. Fine Tuning is accomplished by first setting the standard IP and IB to select a rate as close to the desired rate as possible. Then the FT parameter can be set to bring the rate within 2.5ppm of the target. This method of rate control works with small Tx buffers and gives minimum latency.

Clock Source Options – The transmit clock options include the Black burst clock as well as the Internal Clock. The black burst input accepts a black burst signal for either NTSC or PAL video and is available as an on-board header.

Indicator LEDs – Indicator LEDs are provided near the top edge of the card to show transmitter operation (one LED per channel). The LED will flash to indicate when valid data is being transmitted on that channel.

Null Packet Insertion – Under software control but performed by hardware, "null packets" are automatically inserted into the bit stream.

PCR Pacing – Firmware support is available for releasing PCR packets at the correct PCR time. This method ensures that the transmit rate and PCR timing are the same as the original input stream.

Reed-Solomon Conversion – The software can be set to have hardware add 16 bytes filled with zeros to 188-byte packets to create a 204-byte packet stream.

Conformity to DVB Standards – The DVB Master Quad/o PCIe LP meets CENELEC EN50083-9: 1998 – Cable distribution systems for television, sound and interactive services – Part 9: Interfaced for CATV/SMATV headends and similar professional equipment for DVB/MPEG-2 transport streams.

DVEO
Broadcast Division

Computer Modules, Inc.

11409 West Bernardo Court

San Diego, CA 92127

Tel: 858-613-1818 Fax: 858-613-1815

www.dveo.com